



# Vitae25Bi

## High Output Insert Boiler Stove

Please fix label with serial number and stove type here before putting manual into stove

## Installation and Operating Instructions

Please hand these instructions to the stove user when the installation is complete. Leave the stove ready for operation and instruct the user in the correct use of the appliance and operation of controls.

**Important:** – This product must be installed by a suitably qualified installer.

**Heat Design Ltd.**

30-60 Hawthorn Road  
Western Industrial Estate,  
Naas Road,  
Dublin 12

[www.heatdesign.ie](http://www.heatdesign.ie)

**PLEASE READ ALL THESE INSTRUCTIONS CAREFULLY!**

**For safety reasons it is essential that your stove is correctly installed and operated. Heat Design cannot accept responsibility for any fault or consequential problems arising through incorrect installation or operation.**

## TABLE OF CONTENTS

<b>Section</b>	<b>Page No</b>
1. List of Components	2
2. Component Identification and Installation	2
3. Installation Instructions	3
Warnings and important safety information	3
4 Installation Information	5
Chimney	5
Ventilation	5
Flue Draught	5
Connection to Chimney	5
Material Clearances	5
Hearths	6
Commissioning & Handover	6
5. Technical Data	6
6. Plumbing	7
7. Operating Instructions	10
Air controls	10
Cleaning	11
Fuels	13
Notes on Wood Burning	13
Notes on Burning Solid Fuel	13
Re-fuelling	13
Refuelling onto a Low Firebed	14
Fuel Overloading	14
Shutting down	14
Maintenance	14
Seasonal Use	14
Replacing Door Rope and Glass	15
7. Safety Notes for your Guidance	16
8. Stove Dimensions	17
9. Frequently Asked Questions	18
10. Vitae25Bi Spare Parts List & Codes	19

## List of Components

Description of Parts	Qty
Stove Assembly	1
Tool	1
Ash Pan	1
Thermostat Knob	1
Stove Operating Glove	1
Touch up paint	1
Installation & Operating Instructions	1
Warranty Card	1

Fig 1 – Stove Tool

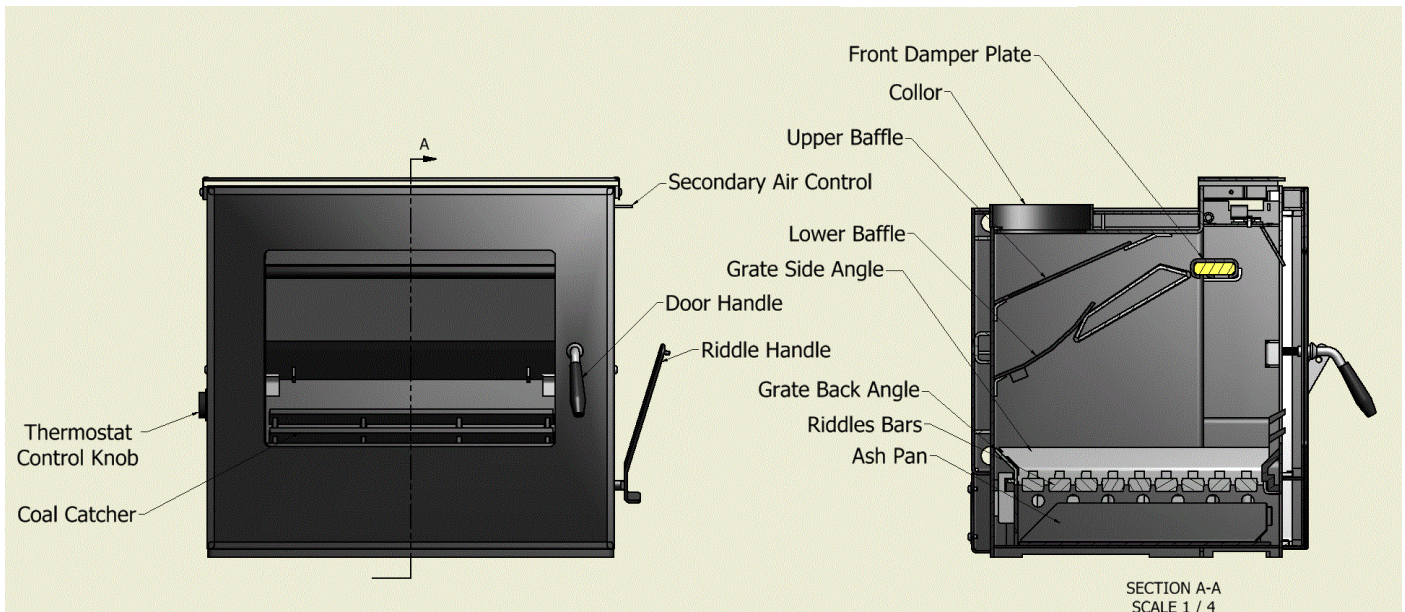
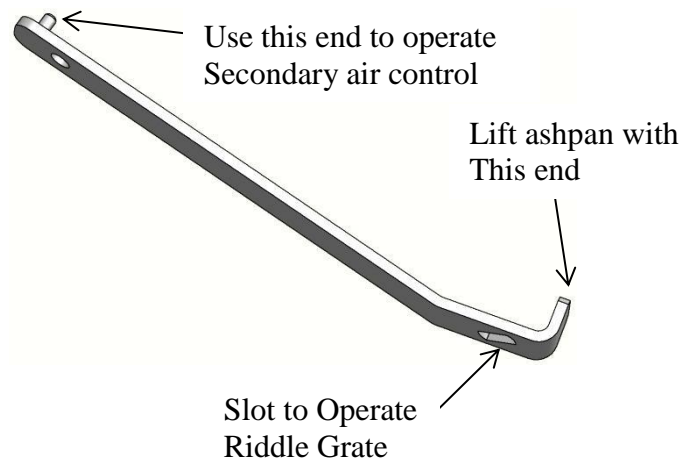

Fig 2 – Insert Boiler Stove Assembly and controls

## 1. Component Identification and Installation

Your Heat Design Stove is shipped securely packed and strapped. Carefully remove any straps and remove all wood, cardboard and any plastic packaging, open the door and remove all the contents. See List of Components section and check contents carefully.

To remove the lower baffle plate, carefully lift it off the two back brackets and remove through the front door. Access can now be gained the upper baffle which can be removed in a similar manner. **Note the orientation of both baffles before removal.** Access to the chimney through the front door of the stove is now possible.

Now proceed to install the stove according to these instructions and current installation standards or HETAS advice. The internal parts of the stove can be re-assembled as the reverse of the previous removal instructions.

## **3 Installation Instructions**

### **WARNINGS AND IMPORTANT SAFETY INFORMATION**

#### **READ THESE INSTRUCTIONS CAREFULLY BEFORE INSTALLATION!**

These instructions cover the basic principles to ensure satisfactory installation of the stove, although detail may need slight modification to suit particular local site conditions. In all cases the installation must comply with current local regulations including Building Regulations, Local Authority Byelaws and other specifications or regulations including Ireland, UK or EU standards referred to as they affect the installation of the stove. Approved Document J is particularly important for England and Wales and can be downloaded for no cost at:

<http://www.planningportal.gov.uk/england/professionals/en/400000000503.html> Also of importance are Approved documents L1 A and B conservation of fuel and power. The Domestic Heating Compliance Guide will also be found useful.

#### **Important Chimney Warning**

This stove must not be installed into a chimney that serves any other heating appliance.

#### **Extractor Fan Warning**

There must not be an extractor fan fitted in the same room as the stove as this can cause the stove to emit fumes into the room.

#### **Cleaning and Chimney Sweeping**

**The appliance, flue & chimney must be cleaned and checked internally and externally regularly in use and especially after a period on disuse (e.g. after summer).** Lift down the baffle at least weekly to check for build up of soot or debris on the top from the flue pipe. Remove the baffle and check the flue spigot and connector is fully clear at regular intervals. The chimney and flue connector must be swept at least annually, more often when used with sooty fuels or damp wood. Any loose, broken or leaking joints or flue ways **MUST** be repaired immediately.

#### **Fuels**

Only use recommended fuels. The appliance can be damaged by burning pallets or treated wood, petroleum coke, anthracite, liquid fuels or general rubbish and this will invalidate your warranty and risk your personal safety. **The appliance must not be used as a rubbish incinerator.** Any coal type fuel that is used must be suitable for a closed appliance. Arigna Ecobrite or similar would be a recommended fuel.

#### **Maintenance**

Annual checking and servicing of the appliance and flue by a competent engineer is recommended.

#### **Ventilation**

Adequate ventilation is **ESSENTIAL** for the safe and efficient operation of any solid fuel or wood burning appliance. Ventilation **MUST** be provided where required by the stove output or flue under-performance. Keep all ventilation clear and free of blockage.

#### **External Ducted Air**

This appliance is suitable to accept ducted external air which should be provided in accordance with best practices and minimum distances to combustibles should be adhered to. It is recommended that a 4" plastic pipe is used to bring the air in from outside. It is recommended to run the air vent from opposite poles of the dwelling and tee off for the air supply to the stove. An aluminium duct should be used to connect from the 4" pipe to the stove. The inlet pipe should be suitable located to prevent ingress of moisture and where it will not get block by leaves or other items. Ensure vent caps are fitted where the vent pipe meets the external wall to prevent the entry of rodents.

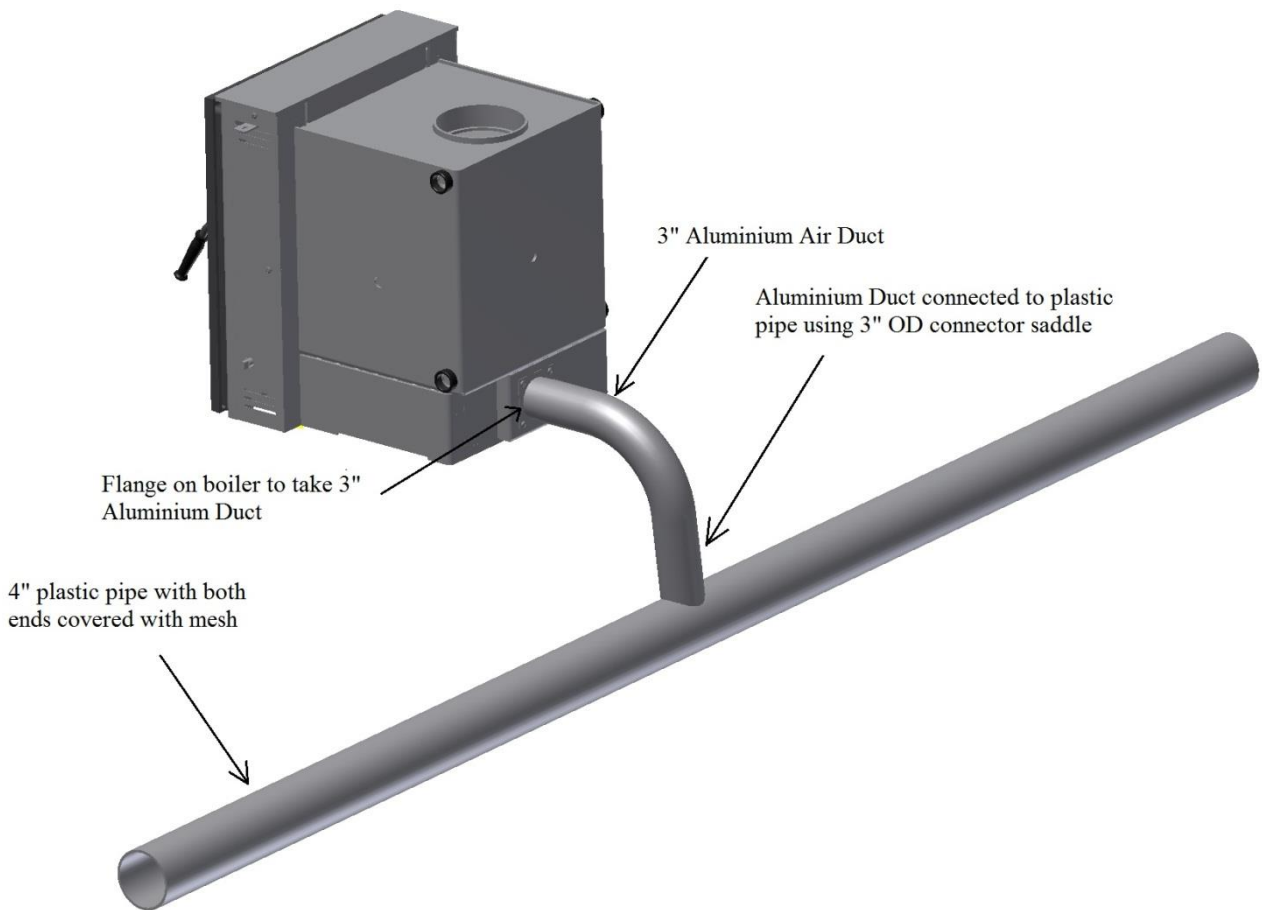

### **Health And Safety Precautions**

#### **Handling**

Adequate facilities must be available for unloading and site handling. Heat Design Stoves are very heavily built so always ask for assistance when lifting and siting the stoves.

#### **Fire Cement**

Some types of fire cement are caustic and should not be allowed to come into contact with the skin. In case of skin contact, wash immediately with plenty of water.

#### **Asbestos**

This stove contains no asbestos. If there is a possibility of disturbing any asbestos in the course of installation then please seek specialist guidance and use appropriate protective equipment.

#### **Metal Parts**

When installing or servicing this stove, proper care should be taken to avoid the possibility of personal injury.

## 4.0 Installation Information

### Chimney

The chimney height and the position of the chimney terminal should conform to Building Regulations. Chimney flue height should be high enough to clear the products of combustion. Check that the chimney is in good condition, dry, free from cracks and obstructions. The diameter of the flue should not be less than 150mm and not more than 200mm. If any of these requirements are not met, the chimney should be lined by a suitable method. The chimney must be swept before connection to the stove.

Where the chimney is believed to have previously served an open fire installation, it is possible that the higher flue gas temperature from the stove may loosen deposits that were previously firmly adhered, with the consequent risk of flue blockage. It is therefore recommended that the chimney be swept a second time within a month of regular use after installation.

If you have any doubts about the suitability of your chimney, consult your local dealer/stockist or chimney specialist. If there is no existing chimney then either a solid fuel compatible prefabricated block chimney or a twin-walled insulated stainless steel flue to BS 4543 can be used. These chimneys must be fitted in accordance with the manufacturer's instructions and Building Regulations.

### Ventilation

Any Room or space containing an appliance should have permanent ventilation opening of free area of 550mm Sq per kw of rated output but in no case less than 6500mm sq where air permeability is greater than 5.0m3, or 6500mmsq +550mmsq per kw of rated output above 5 Kw where the air permeability is less than 5.0m3. "Note: If there is another appliance using air fitted in the same or adjacent room, it will be necessary to provide an additional air supply." **Ref Building Reg's Document J**

### Flue Draught

A flue draught of minimum 1.6mm to a maximum 2.5mm water gauge (16.5 to 25 Pascals) is required for satisfactory appliance performance. The flue draught should be checked under fire at high output and, if it exceeds the recommended maximum, a draught stabiliser must be fitted so that the rate of burning can be controlled to prevent over-firing.

### Connection to the Chimney

This appliance is **not** suitable for use in a shared flue. This appliance requires a direct flue connection to the spigot. It is **essential** that all connections between the stove and chimney-flue are sealed and made airtight with sealing rope, clamping rings and/or fire cement or heat resisting cement where required.

Both the chimney and flue pipe must be accessible for cleaning and if ANY parts of the chimney cannot be reached through the stove (with baffle removed), a soot door must be fitted in a suitable position to enable this to be done.

In adverse weather conditions, downdrafts may occur causing smoke or fumes to spill into the room. If this occurs the appliance should be shut down as much as possible by closing the air controls and the room should be ventilated to clear the fumes. If the problem persists seek the advice of a chimney sweep.

### Material Clearances

#### Safety Distances from Combustible Surfaces:

Model	Back	Side	Shelf
Vitae25Bi	150mm	150mm	550mm

In addition ensure that any furniture or other combustible materials are kept at least 1000mm clear from the front of the stove.

### **Distances from NON-combustible materials:**

To conform with building regulations the fireplace recess walls should be at least 200mm thick or each rear leaf at least 100mm thick in the case of a cavity wall at the rear. If these dimensions are not met further protection for any combustible materials must be provided. The walls of the fireplace recess and the hearth must be made of non-combustible material.

### **Hearths:**

Heat Design stoves require a 125mm thick non-combustible constructional hearth beneath them to protect the building, this can include any solid non-combustible floor. A non-combustible superimposed hearth forming an apron of at least 225mm at the front of the stove and 150mm on either side must also be provided. The superimposed hearth must not be less than 12mm thick and must have a clearly defined edge (change of level) to discourage placing of any combustible materials on or partially over it.

The appliance shall be installed on a floor with adequate load-bearing capacity. If the existing construction does not meet this requirement, suitable measures (e.g. load distributing plate) should be provided to achieve it.

### **Commissioning and Handover**

Upon completion of the installation, allow a suitable period of time for any fire cement and mortar to dry out. A small fire may then be lit and checked to ensure the smoke and fumes are taken from the stove up the chimney and emitted safely to atmosphere.

Advise the customer not to run the stove at full output for at 3 – 4 days. Explain that the stoves can provide much more or less than their rated heat outputs depending upon how they are burnt and fuels and fuel loads used.

On completion of the installation and commissioning, ensure that the operating instructions and operating tools (including glove) for the stove are left with the customer. You must be sure to advise the customer on the correct use of the appliance with the fuels likely to be used on the stove and warn them to use only the recommended fuels for the stove.

Advise the user on what to do should smoke or fumes be emitted into the room from the stove – see **Safety Notes** section. The user should be warned that they **MUST** use a suitable fireguard in the presence of children, aged and/or infirm persons.

## **5.0 Technical Data**

<b>Technical Specifications</b>		<b>Wood</b>	<b>Coal</b>
Nominal Heat Output	kW	25.2	22.6
Nominal Heat to Water	kW	16.2	15.9
Nominal Heat to Room	kW	9.0	6.7
Efficiency	%	74.3	77.1
CO Emission (@ 13% O <sub>2</sub> )	%	0.44	0.18
Flue Gas Temp (avg. at nominal output)	°C	409	360
Refuel Period	hr	1.0	1.0
Flue Outlet Size	mm	153	153
Product Weight - Net	kg	185	185
Maximum Log Length	mm	450	N/A

## 4.0 Plumbing

This appliance must be plumbed in accordance with all regulations and practices and plumbing must be carried out by a suitably qualified professional. The plumbing circuit must include a gravity circuit with an expansion pipe open to the atmosphere. Below are several diagrams representing different plumbing circuits. These are not working drawings and are for example only. Designs and calculations for individual systems should always be carried out by a suitably qualified heating engineer.

**Fig. 3** – Connecting the stove to an existing Heating System with oil/gas as primary heat source.

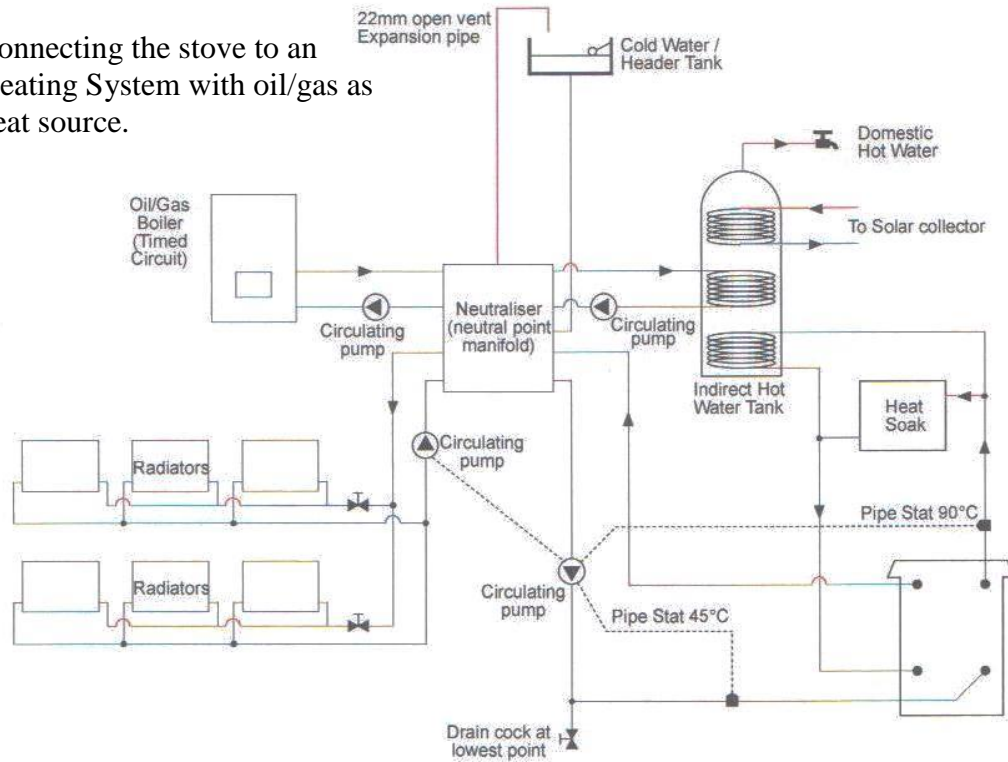

**Fig. 4** – Central Heating system with the stove as the primary source of heat (indirect). All four tappings on the stove are used.

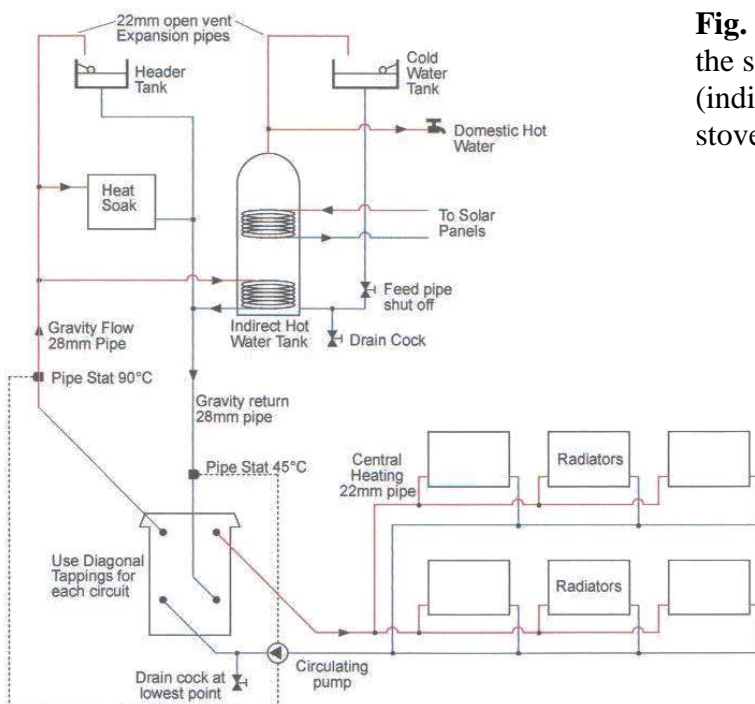



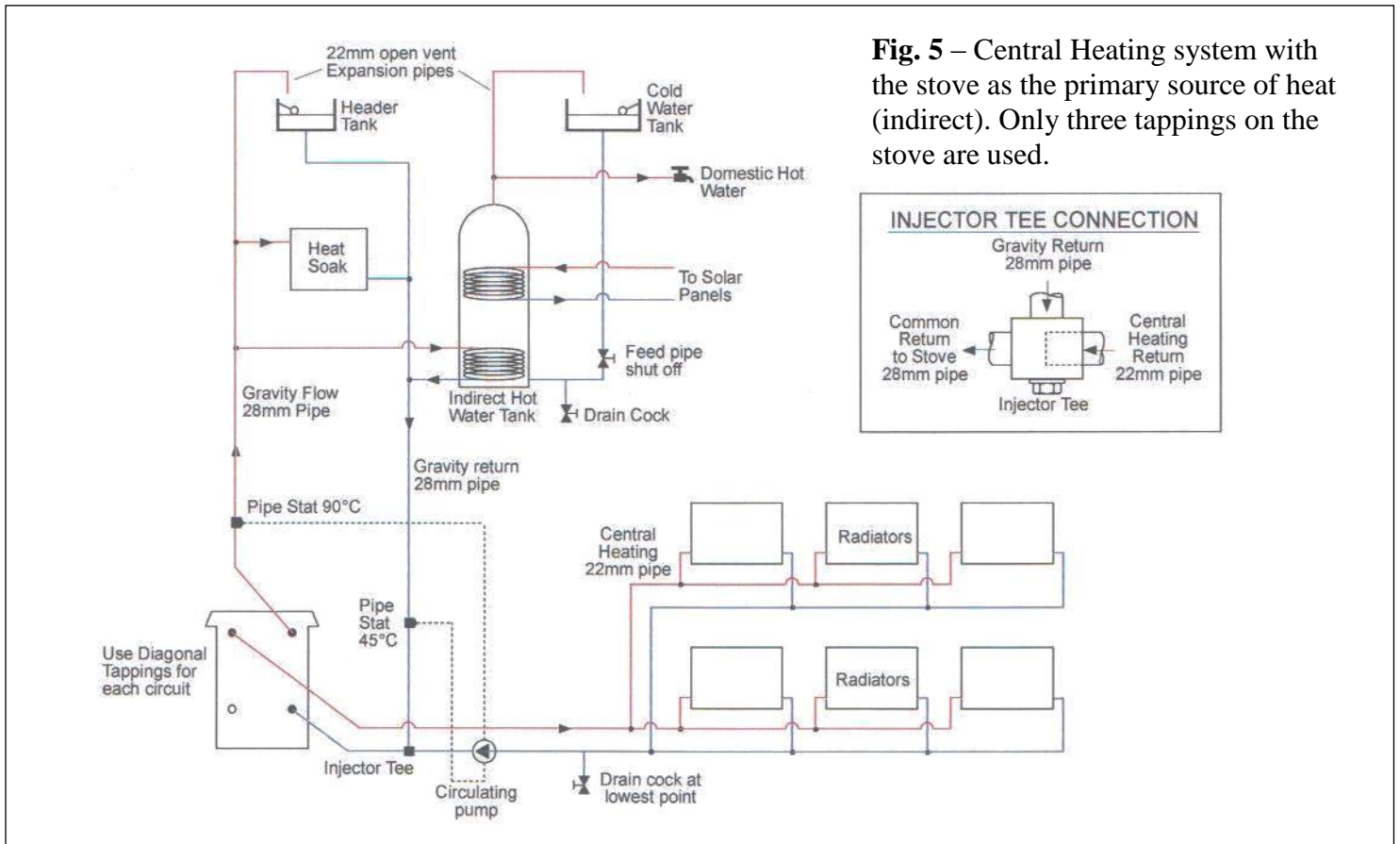

**Fig. 5** – Central Heating system with the stove as the primary source of heat (indirect). Only three tapplings on the stove are used.

**It is strongly recommended that this stove is fitted to your heating system by a knowledgeable, experienced and suitably qualified (Hetas or equivalent) plumber or Heating Engineer with experience in fitting boiler stoves. If fitted incorrectly it could result in serious damage to your home heating system. Plumbing should be carried out in accordance with Relevant Building Regulations and safe practices. The manufacturers cannot be held responsible for any losses due to incorrect specification or connection of the heating system.**

**This Heat Design Boiler Stove must always be connected with the flow and return connections on opposite sides of the appliance (cross-flowed) to an indirect hot water system. Fernox or a similar corrosion inhibitor should be used to prevent corrosion or formation of limescale in the heating system.**

### Gravity Circuit

**Do Not** – Under any circumstances connect the stove to a sealed (pressurised) heating system or an unvented HW cylinder

**Do Not** – Link the stove into a heating or hot water system with an existing boiler without the use of suitable equipment such as a neutralizer. When fitting this type of system the neutralizer manufacturer's instructions must be followed.

**Do** – Fit an open cold feed and header expansion tank with separate cold feed and vent pipes. The cold feed and vent pipes must be unvalved. The open vent pipe should have a diameter of 22mm and rise continuously from the boiler.

**Do** – Connect the flow and return connections on opposite sides of the appliance

**Do** – Fit pipe stats to control the radiator circulation pump as instructed to prevent cold water corrosion

The gravity circuit should connect to a domestic indirect hot water cylinder of minimum 135lt capacity, using 28mm flow and return pipes, rising continuously from the boiler to the cylinder. Any nominally horizontal runs of gravity pipework should slope upwards at not less than 1:30. The base of the hot water cylinder should be located at least 150mm above the top of the stove. The gravity circuit must not contain any shut off valves and should be fully lagged to minimise heat loss. The pipes should not exceed 7.8 meters (25ft) in length to/from the cylinder. In general, the shorter the run of pipework the less heat loss and the more efficient the water heating.

A heat soak radiator of at least 2kW must be used on the same gravity circuit, positioned above the stove. This is used to dissipate heat when the central heating is switched off or the HW cylinder is fully heated.

### **Link Up:**

On heating and hot water installations, a semi-pumped system should be used to the central heating system with gravity circulation to the hot water cylinder. For optimum performance of the boiler we recommend that all 4 tappings are used when using separate gravity and pumped heating loops. The flow and return pipes should be taken from diagonally opposite sides of boiler.

### **Injector Tee:**

If only two tappings are used on a common flow system, they should be taken diagonally opposite and the remaining tappings should be plugged. An injector Tee should be fitted to join the gravity feed and central heating circuits back to the stove, which should be situated as close to the stove as possible. The tee connection encourages the stable flow of water through both circuits and prevents priority being given to the stronger flow, typically the pumped circuit.

### **Pipe Thermostats**

A HIGH LIMIT thermostat should be fitted to the gravity flow pipe close to the boiler and set at 90°C. This should override any pump control, switching the pump on and dissipating any excess heat around the radiator circuit. To prevent boiler corrosion due to condensation it is necessary to maintain the return water temperature above 45°C. This can be achieved by the use of a LOWLIMIT thermostat on the return pipe from the hot water cylinder, close to the boiler. The thermostat should make on temperature rise, preventing the circulating pump from operating until the gravity circuit is up to temperature.

### **FAILURE TO COMPLY WITH THE ABOVE REQUIREMENTS WILL INVALIDATE THE GUARANTEE**

### **Commissioning and Handover**

Upon completion of the installation, allow a suitable period of time for any fire cement and mortar to dry out. A small fire may then be lit and checked to ensure the smoke and fumes are taken from the stove up the chimney and emitted safely to atmosphere. Do not run the stove at full output for at least 3 – 4 days.

On completion of the installation and commissioning, ensure that the operating instructions and operating tools for the stove are left with the customer. Ensure to advise the customer on the correct use of the appliance with the fuels likely to be used on the stove and warn them to use only the recommended fuels for the stove.

Advise the user on what to do should smoke or fumes be emitted from the stove. The user should use a suitable fireguard in the presence of children, aged and/or infirm persons.

All connections to the boiler should be checked to ensure there are no leaks during operation and that the flow and return water connections are working properly. The stove should be fired up initially by the Plumber / Heating Engineer to ensure that it is operating safely with the rest of the heating system.

## **5.0 Operating Instructions**

This appliance is not designed for open operation and therefore should **not** be operated with the doors open.

This stove is designed to burn cleanly with high efficiency. If used correctly this stove will burn with the very useful feature of clean glass. However, for this product to work properly it must be used correctly.

It is **essential** that the stove has an adequate air supply for combustion and ventilation. The primary and secondary air inlets must be kept clear from obstruction.

**Warning!** This appliance will be very **hot** when in operation and due care should be taken when operating the controls. A leather glove is provided to assist safe operation.

Do not use an aerosol spray on or near the stove when it is alight.

### **Air Controls**

#### **Primary Air**

Primary air is controlled via the thermostat control at the left hand side of the stove. The thermostat is the primary source of under grate air for the stove. When a position between minimum and maximum setting is chosen the thermostat will open and close automatically to regulate the amount of fuel burned and the amount of heat produced. A trial and error approach will establish settings to suit personal preference.

#### **Secondary Air (Air Wash)**

This Heat Design boiler stove has a powerful “air wash” system. This secondary air supply to the stove is controlled via a sliding air control located on the top right of the stove. If you want clean glass, always leave this control open some way whilst burning unless the stove is being shut right down for a long period. Moving the sliding control towards the wide side of the arrow increases the burn rate whilst moving it towards the narrow side reduces it.

#### **Multifuel Grate**

This High Efficiency Heat Design Boiler Stove has a grate which consists of individual High Chrome bars which are connected by a patent pending easy removal system which ensures that all bars rotate together when the riddle lever on the outside of the stove is operated. This ensures easy and thorough de-ashing of the stove, whatever fuel is being used. The unique 30° reciprocating motion of the grate ensures effective operation even in the most difficult circumstances.

#### **Assembly of the Grate**

Your Heat Design stove comes with the grate fully assembled (see fig 3a). Periodically the grate may need to be disassembled to give the stove a thorough cleaning. This might be done once a year at the end of the heating season, for example. It is easier to re-assemble the grate if all the bars are **not** removed at the same time. First remove the coalcatcher by lifting it up and through the door of the stove. Then remove the side angles by lifting them up at the front, pull them forward to release the tabs at the back and remove from the stove. Leave the front and back bars in place and remove all the other bars first (See fig 3b). Clean away any ash or debris that is present. Replace the middle three bars and then remove the front and back bars (see fig3c). Finish cleaning and replace the remaining bars. Removing and replacing the bars in this way will ensure that the joining bar remains in position during the process. Replace the remaining bars and the angles and coalcatcher in the reverse of the order in which they were removed.

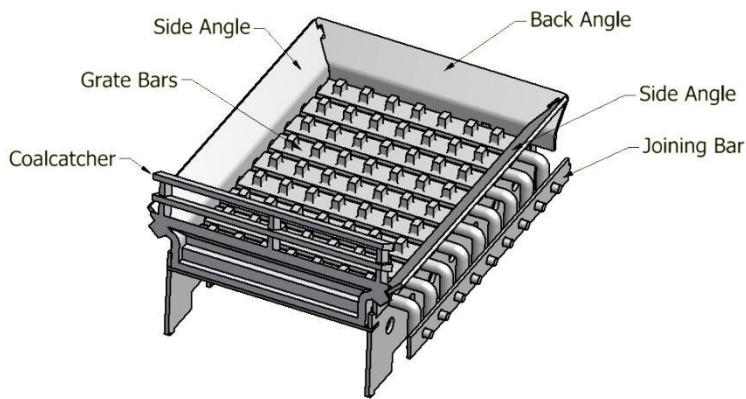

Fig 6a – Full grate assembly

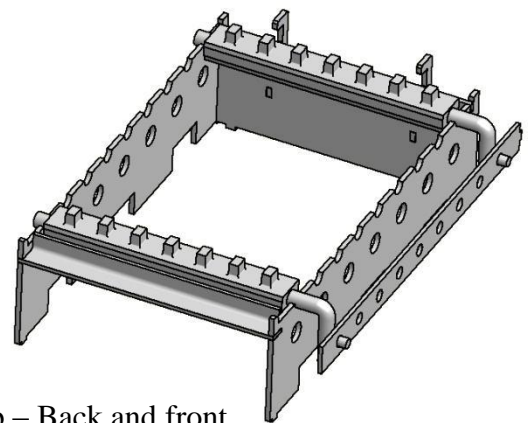

Fig 6b – Back and front bars on grate

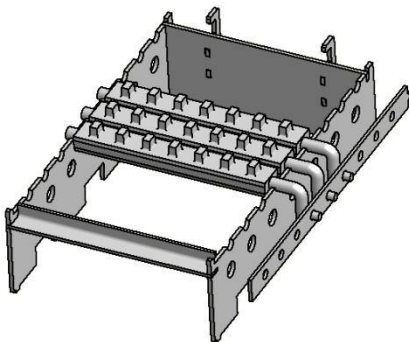

Fig 6c – Replace middle three bars and then remove front and back bars

The grate bars also need to be checked periodically for any signs of extreme wear and may need to be replaced as necessary. All bars are the same and the spare part code can be found at the back of this manual.

### Ashpan

It is essential that you empty the steel ash pan every day. Use the thick end of tool to hook onto and lift the ash pan out of the stove. **DO NOT allow ash to build up underneath the bed as this may cause damage to the grate.**

### Cleaning

**Always ensure that the stove is fully cold before attempting any of the cleaning procedures outlined below.**

#### **Glass:**

Despite the advanced air wash system provided, the glass will still need cleaning from time to time depending on the fuel quality and burning rates used. Never clean glass when the stove is hot. Always use stove glass cleaner or ceramic hob cleaner, which is available from your stove retailer. As an alternative, use a wet cloth with some of the wood ash if burning wood but be very careful to use very clean ash so as not to scratch the glass.

#### **Outer body:**

The outer body simply needs to be dusted from time to time. **DO NOT** use any kind of furniture polish or cleaning agent other than your stove suppliers recommended paint.

#### **Inner firebox:**

Brush the inside of the firebox clean from time to time to check the integrity of the plates and liners etc. It is not normally necessary to re-paint inside the firebox due to the high temperatures that mean that the paint

does not have much effect before being burnt off. Steel and cast iron liners are resilient firebox materials and will give reliable service without major cleaning or work on the firebox.

**Baffle:**

It is essential to check the top of the baffle for build-up of soot and ash regularly when in use and after a long period of no use. From time to time remove the baffle if necessary to ensure that the flue way entrance is clear. Take note of the baffle orientation when removing and ensure it is refitted the same way.

**Thermostat:**

It is very important to occasionally clean around the thermostat to ensure proper operation of the damper as this regulates the amount of primary air and hence the burn rate of the stove. Firstly, remove the thermostat knob by pulling it gently away from the thermostat and then remove the Left Side Casing by undoing the two fixing screws. Then clean any ash that has built up around the damper of the thermostat and open and close the thermostat to ensure that it is working properly. In the closed position it should seal tightly against the body of the stove (see diagrams below)

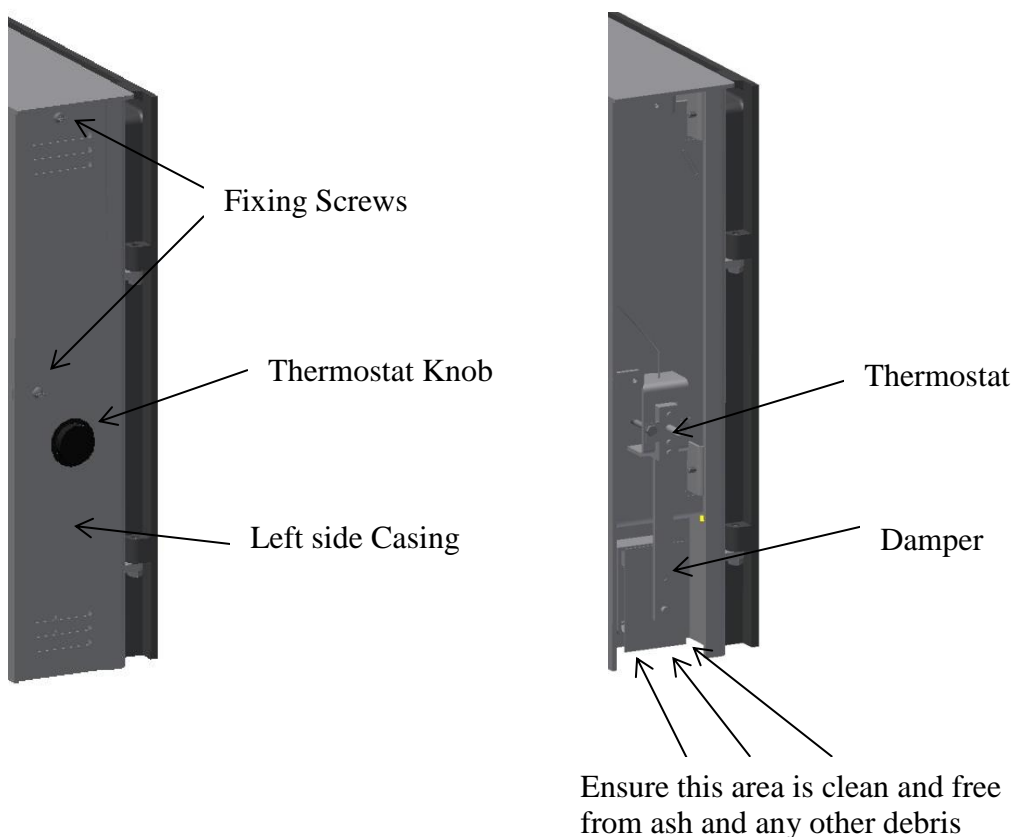

**Ashpan area**

There are cleaning slots present in this area to ensure that any ash or debris that builds up between the ash box compartment and the outer jacket of the boiler can be removed and hovered up. Use a screwdriver to loosen and tease out the ash and debris and it can then be hovered away as shown below. Repeat on opposite side.

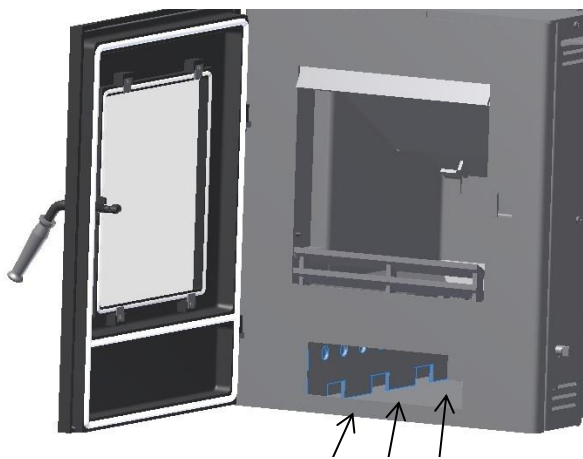

Ash Removal Slots

## **Fuels**

The appliance is fitted with a versatile multifuel grate and has been tested using dry wood (less than 20% moisture) and coal (Manufactured smokeless nuggets, Ecobrite or similar).

## **Notes on Wood burning**

With a full load of wood, the stove will need to be refuelled approximately every hour depending on burn rate. Wood can be stacked in the stove but care must be taken that logs do not touch the baffle. Do not stack fuel so high that it touches the middle waterway in the stove,

Always make sure that flames are visible above the wood after re-fuelling for cleanest burning. Open the air wash full for 1 to 2 minutes to achieve full flames above the fuel. Carefully adjusting the secondary air controls and fuel load will then control the burn rate of the stove. Wood burns most efficiently with the primary air controls slightly open and the secondary (air wash) controls open about 25-50%. The secondary air must always be open to keep the glass clean

**See also:** section entitled 'Lighting the Stove'.

Wood burns best on a bed of ash and it is therefore only necessary to remove surplus ash from the stove occasionally. **If the grate is completely clear, place a few handfuls of ash into the slots in the grate to help the firebed build up.**

Burn only dry, well-seasoned wood, which should have been cut, split and stacked - under protection from rain - for at least 12-24 months with free air movement around the sides of the stack to enable it to dry out. Burning wet or unseasoned wood will create tar deposits in the stove and chimney and will not produce a satisfactory heat output. **Wood that is not properly dry ('dry' is considered to be less than 20% internal moisture content) uses up energy from the burn process to evaporate the water inside the wood thus creating very poor conditions for combustion.** The main cause of burning problems with wood stoves is due to excessively damp wood. Wood can appear perfectly dry on the outside but still contain 40-50% water on the inside. A moisture meter can be purchased from some stove and equipment suppliers if you wish to check your wood source is correct.

## **Notes on Burning Solid Fuel**

See section 6.6 on lighting the stove. After the fire has become established close the airwash until it is approximately 25% open and use the primary air control to set the burn rate. De-ash the stove by stoking the fire before adding new fuel. Open the primary air 100% for a few minutes before refuelling to establish a good hot bed. Leave the primary air fully open for 4-5 minutes after adding the new fuel and then adjust until approximately 50% open to achieve nominal output. With experience you will learn to adjust the controls to establish personal settings. It is better to refuel little and often, this burns the fuel more efficiently and prolongs the life of the stove.

## **Re-fuelling**

When burning wood, the fire will die down as the fuel is consumed. When the flames disappear and the remainder is breaking down into glowing embers it is an appropriate time to consider re-fuelling. NOTE: If

the flames disappear and there are still lumps of solid wood left this indicates excessive moisture in the wood or insufficient air supply/flue draught.

**Note:** To eliminate unwanted smoke emission, after loading new logs on to the fire, open the air wash control up fully for 1-2 minutes to boost the fire and get flames issuing from the top of the fuel as soon as possible. When flames are well established, reduce the air wash to the running setting required. Burning without flames above the fuel will create unnecessary smoke. Do not operate the appliance with the air controls fully open for a prolonged period as it will cause over firing and may result in smoke being produced.

Loading 1 to 2 medium sized logs will produce a good output with reasonable burn time, generally small logs will burn up quicker producing a high output for a short time and a large log will take longer to burn and produce less output over a given time. These appliances are approved for intermittent operation on wood (0.75 to 1.5 hour burn cycles) although much longer burn times can be achieved by fully loading the firebox, getting the fuel burning well and then shutting the air controls down. The fire will then often need reviving by first de-ashing and then using small pieces of wood and plenty of air to get flames issuing from the wood again.

### **Refuelling on to a low fire bed**

If there is insufficient burning material in the fire bed to light a new fuel charge, excessive smoke emission can occur. Refuelling must be carried out onto a sufficient quantity of glowing embers and ash that the new fuel charge will ignite in a reasonable period. If there are too few embers in the fire bed, add suitable kindling to prevent excessive smoke

### **Fuel Overloading**

Four good size logs is a sufficient quantity of fuel to achieve the rated output from this appliance. Never exceed this amount of fuel and never stack the fuel too high in the stove so as it touches the baffle or blocks the tertiary air holes as this may cause smoke to be produced.

### **Shutting Down**

The stove will normally shut down by itself as the fuel is consumed. In order to shut down the stove for other reasons, close the primary air controls (if open), then close the secondary air control. If the controls are left in this position, the fire will eventually burn out. If you want to revive the fire open the secondary air controls fully.

**Warning!** - The stove will remain **very hot** for a considerable time after the fire has died down or been extinguished.

**Warning!**- **Petroleum coke fuels or household waste must not be burnt on this appliance.**

### **Seasonal Use**

Remove the baffle and inspect the inside of the stove and the flue ways and ensure they are 100% clear after a period of disuse, for example if the stove is not used during the warmer periods of the year. Also set the air controls to 50% to keep the appliance ventilated and stop the build-up of any moisture inside.

### **Maintenance**

Inspect the inside of the firebox and above the baffle plate every week during use. **See chimney cleaning section in section 3.1 Warnings and Important Information.** Inspect the inside of the stove and the flue ways and ensure they are 100% clear after a period of disuse (e.g summer). **Only use manufacturers recommended replacement parts on the appliance (see page 19 for full list of spare parts).**

## Replacing Door Rope and Glass

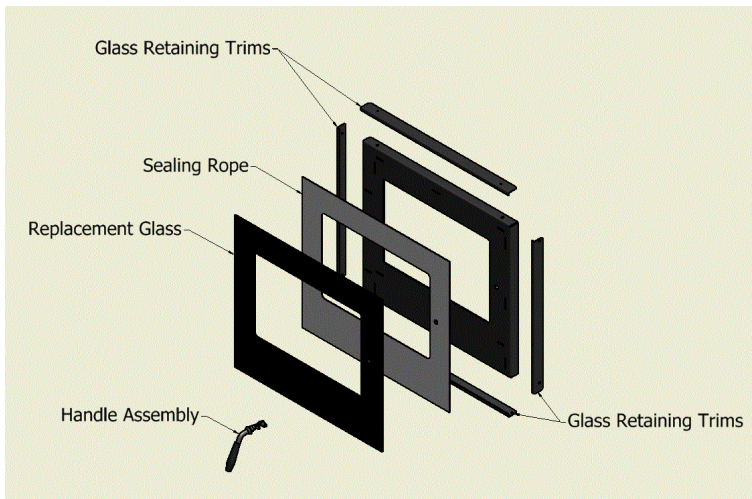

Remove the handle assembly, then remove the door from the stove and lay it on its back. Then remove the 4 glass retaining trims. Carefully replace the broken glass. Ensure the sealing rope behind the glass is fully intact, replace if necessary. Replace the glass with genuine high quality stove glass from Heat Design and refit all components the opposite way you disassembled.



## **6.0 Safety Notes for your guidance**

**FIRES CAN BE DANGEROUS** – Always use a fireguard in the presence of children, the elderly or the infirm.

**DO NOT perform modifications to the appliance as this could seriously compromise safety in operation.**

**DO NOT OVERFIRE** – it is possible to fire the stove beyond its design capacity, this could damage the stove, so watch for signs of over firing – if any part of the stove starts to glow red, the fire is in an over fire situation and the controls should be adjusted accordingly. Never leave the stove unattended for long periods without first adjusting the controls to a reduced and safe setting – careful air supply control should be exercised at all times.

### **WARNING – FUME EMISSION**

Properly installed and operated, this appliance will not emit fumes. Occasional fumes from de-ashing and refuelling may occur which is not normally of serious concern. **However, persistent fume emission is potentially dangerous and must not be tolerated.**

If fume emission does persist, then the following immediate action should be taken: -

1. Open doors and windows to ventilate room
2. Let the fire out, or remove and safely dispose of fuel from the appliance.
3. Check for flue chimney blockage and clean if required.
4. Do not attempt to re-light the fire until the cause has been identified and corrected.

If necessary, seek professional advice from chimney or stove specialists.

**Important!** – Do not fit an extractor fan in the same room as this appliance.

### **IN THE EVENT OF A CHIMNEY FIRE**

- Raise the alarm to let others in the house know.
- Call the Fire Brigade
- Reduce the appliance-burning rate by closing all air controls fully.
- Move furniture and rugs away from the fireplace and remove any nearby ornaments.
- Place a fireguard or spark guard in front of the stove.
- Feel the chimneybreast for sign of excessive heat.

If the wall is becoming hot, move the furniture away. Ensure that the Fire Brigade can gain access to your roof space in order to check this area for signs of fire spread.

## 8.0 Stove Dimensions

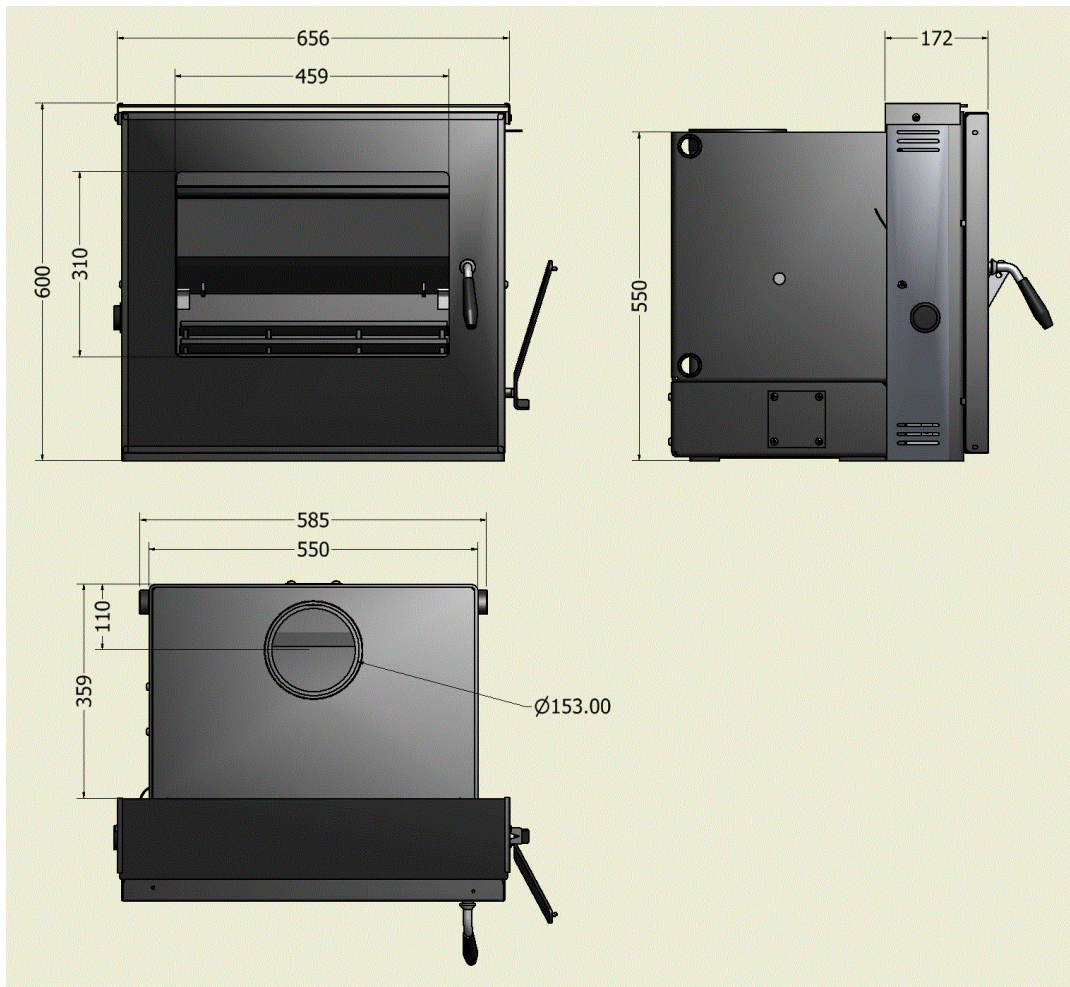

**Fig. 7 – Heat Design Insert Boiler Stove**

All dimensions in mm unless otherwise stated.  
Dimensions are approximate and are subject to change without prior notice.

## **9.0 Frequently Asked Questions**

*1 Do stoves require a chimney? All of our multi fuel and wood burning stoves require a suitable chimney or professionally installed flue system.*

*2 How do I clean the chimney? You will require a chimney sweep to clean the chimney. It is essential to provide a dedicated chimney cleaning access door when installing the flue of the stove in some situations. In other situations the chimney can be swept through the firebox.*

*3 Who should install my stove? Heat Design Stoves want you to enjoy the maximum performance from your appliance. To ensure this, it is essential that they are installed correctly. We strongly recommend that your stove is installed by a suitably qualified installer e.g HETAS.*

*4 How do I regulate the heat output? Each stove has various air controls, which will allow you to easily regulate the heat output and refuelling rate.*

*5 What warranty do I get? Heat Design Stoves will replace, free of charge, any working part that fails (under normal operating conditions) within 12 months of purchase. Consumables such as glass, firebox lining boards or stove rope and adhesives are not guaranteed. **A call out charge will apply if our engineer attends any stove problem that is not related to product failure.***

*6 Where can I get spare parts? Your local Heat Design Stove retailer will be pleased to supply spare parts and to provide any other information you require.*

*7 Can the doors be left open while burning? **No**, for safety and heat efficiency the doors should remain closed.*

*8 Why is the stove smoking when lit? A flue with back draught problems is almost certainly the cause of a smoking stove. Also check adequate ventilation is present. A qualified fitter should complete both a smoke pressure and flow test prior to fitting the stove to ascertain the integrity of the flue.*

*9 Why should I "Run in" my stove? To begin, light a series of small fires over a period of a few days to allow the paint finish to cure. The stove is finished with a highly heat resistant paint. The finish can be renovated with stove paint available from your local stove retailer. If the stove is not "run in" correctly, this may cause the paint to discolour and flake.*

*10 What is Over Firing? Your stove should never be used in a manner to cause over firing. Over firing can be caused by over loading the stove with fuel, and with primary controls open. If any part of stove glows "red" your stove is over firing and your draught control should be adjusted to restrict airflow to stove. Over firing can cause permanent damage to the appliance, which is not covered by warranty.*

***Always adhere to building reg's & doc J***

# 10.0 Vitae25Bi Spare Parts List & Codes

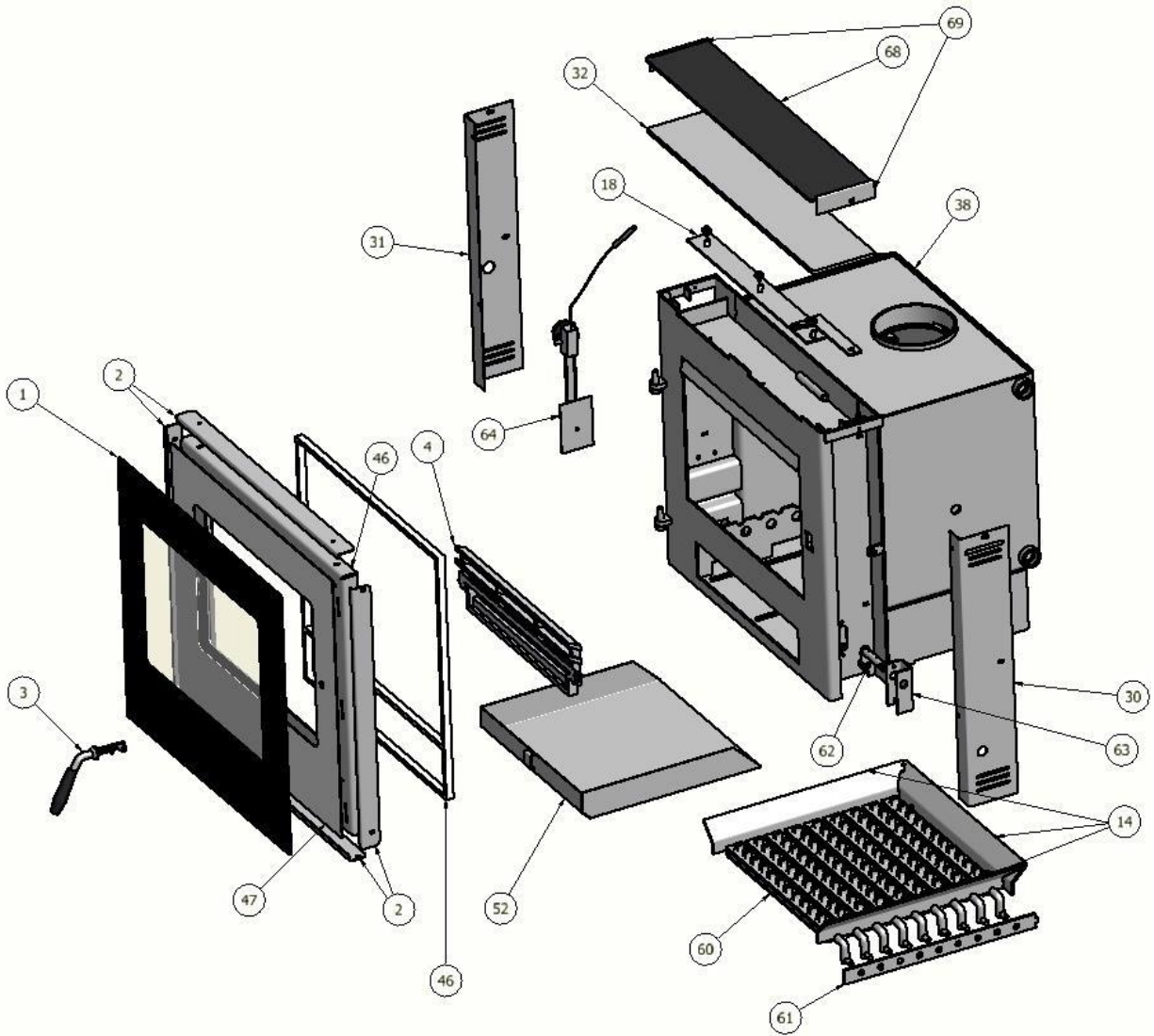

	Component	Vitae25Bi		Component	Vitae25Bi
01	Door Glass	Y1HDI18B01A	31	Side Left	Y1HDI18B37A
02	Glass Brackets and Screws	Y1HDI18D02E	32	Top	Y1HDI18B38A
03	Door Handle assembly	Y1HDI18B03A	38	Boiler shell	Y1HDI18B45A
04	Coalcatcher	Y1HDI18B04A	44	Door Hinge/Pin	Y1HDI18B51A
14	Grate Angles (boiler only)	Y1HDI18B17A	46	Rope Ø14mm (cut to size)	Y1HDI18B54A
16	Baffle Plate	Y1HDI18B19A	47	Rope Ø5 (full roll)	Y1HDI18B55A
17	Baffle Plate Upper	Y1HDI18B20A	60	Grate Bars	Y1HDI18B68A
18	Airwash slider plates	Y1HDI18B21A	61	Grate bars joining bar	Y1HDI18B69A
22	Ashpan	Y1HDI18B28A	62	Riddle Handle Assembly	Y1HDI18B70A
23	Glove	Y1HD29E	63	Riddle Handle Bracket	Y1HDI18B71A
25	Ashpan Tool	Y1HDI18B31A	64	Thermostat	Y1HDI18B72A
26	Door	Y1HDI18B32A	65	thermostat knob	Y1HDI18B73A
30	Side Right	Y1HDI18B36A	66	Front Damper Plate	Y1HDI18B74A

Heat Design, 30-60 Hawthorn Road, Western Industrial Estate, Naas Road, Dublin 12.

T: 01 408 9192

F: 01 408 9193